



HAWK LADDER

ESCALERA TIJERA DOBLE ACCESO DE ALUMINIO

FICHA TÉCNICA



Tapa completa de aluminio reforzado

Peldaños con superficies antideslizantes y doble remache de fijación

Tirantes separadores antipelizco

Refuerzos en los peldaños

Zapatas de aluminio reforzadas con jebe antideslizantes

VISTA FRONTAL

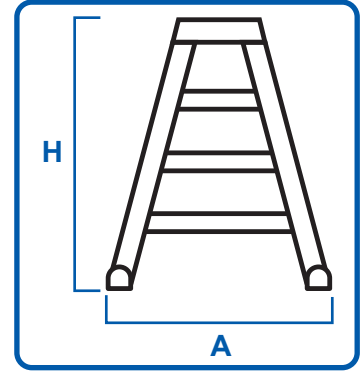

VISTA LATERAL

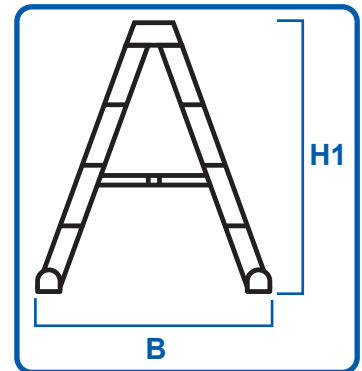

200
kg-max



ESPECIFICACIONES

DIMENSIONES EN METROS (m)

Modelo	Pasos	Peso	Capacidad Maxima	Altura cerrado (H)	Altura Abierto (H1)	Ancho Frontal Inferior (A)	Apertura Abierto (B)
ATD200-4IA	4	5.25	200 kg	1.22	1.13	0.47	1.08
ATD200-5IA	5	6.45	200 kg	1.53	1.44	0.51	1.19
ATD200-6IA	6	7.40	200 kg	1.83	1.73	0.56	1.37
ATD200-7IA	7	8.70	200 kg	2.13	2.01	0.59	1.57
ATD200-8IA	8	10.20	200 kg	2.44	2.30	0.64	1.75
ATD200-10IA	10	15.25	200 kg	3.05	2.87	0.71	2.15
ATD200-12IA	12	19.45	200 kg	3.66	3.46	0.79	2.54
ATD200-14IA	14	23.40	200kg	4.27	4.03	0.87	2.94
ATD200-16IA	16	29.25	200 kg	4.88	4.60	0.95	3.38

La garantía aplica solo por algún defecto de fábrica